



# RZR PRO Turn Signal System

Thank you for purchasing XTC Power Products Automatic Self-Canceling Turn Signal System. Our Easy-Install Turn Signal System is unique from the other kits on the market. This kit is from our Plug & Play™ product line, no wires to cut, no crimping, plugs into OEM Pulse Power System for Power. We use our Patented System that plugs into the OEM Taillights, utilizing the Brake Lights as Brake and Turn Signals.

Please read the instructions fully and familiarize yourself with the components before starting the installation. The diagram below shows the overall system layout.

## ATS-POL-M24 Automatic Self-Canceling Turn Signal System

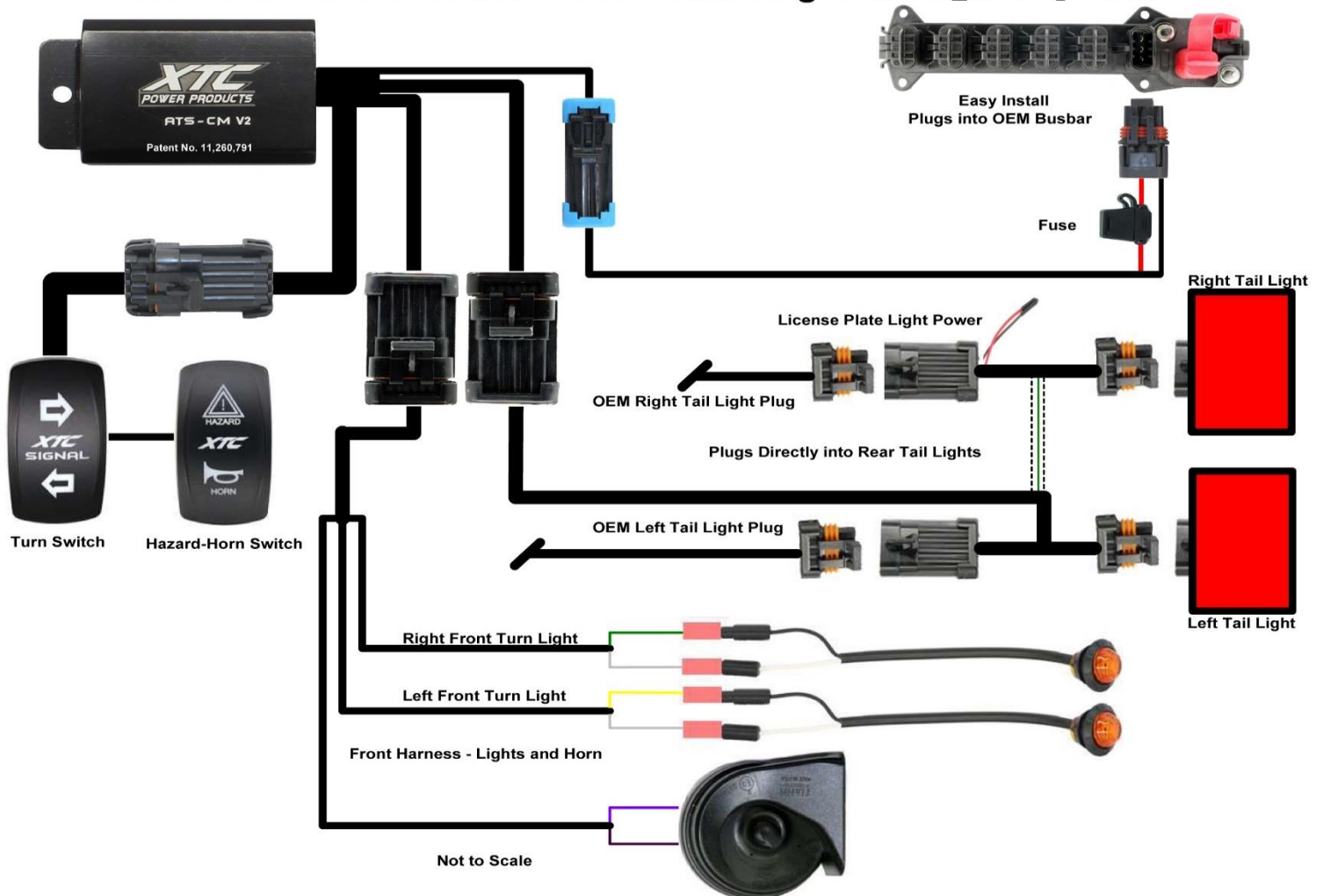

1. Install Rear Light Harness - Take the long rear harness with five connectors and unroll. Remove the 4 Torx T-40 screws holding the bed box in and remove.
2. The Harness is installed In-Line with each rear taillight. At the Drivers Side rear OEM taillight, unplug the 4-Pin connector and plug the connector with a yellow wire into the taillight, then plug the removed factory connector into the Harness.

Run the other 4 Pin connectors with a green wire across to the passenger side, run along OEM harness, plug into passenger side taillight, then plug the removed factory connector into the Harness, secure the harness with included Zip Ties.



**WARNING!** Make sure to keep the harness away from any hot or moving parts.

Remove the driver's side Rocker panel and front fender, exposing the side chassis and fender support.



Run the rear harness from the taillight down along the frame to the main wire harness where there is a large rubber grommet behind the OEM battery relay going through the rear fire wall, push the connector through the grommet.



Run along the left side frame from the rear to the front left fender.

**Grommet with connector showing**



Open the Dash storage and remove the tray, run the harness up into the compartment.

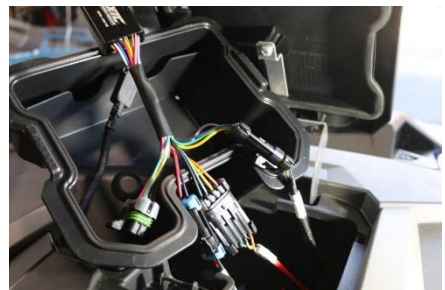

Go up the fender support into the dash. Plug into the Control Module.

**WARNING!** Verify that there is clearance where you want to mount the front LED lights before drilling the holes!

3. Front LED Turn Lights – The front LED Turn Indicators can be mounted with the rubber grommet or without. If the grommet is **not** being used drill 5/8" holes. If the grommet is being used drill 3/4" holes. Remove and install the rubber grommet from the LED into the hole if being used. Insert LED into the hole with the Top marking up. NOTE: the TOP marking is on the front of the LED lens. Drill and install the Front LED Lights.



4. Run the Front short harness through the rubber fire wall grommet and plug into the Control Module shown above. Make sure to run both wires over the front frame/shock mount to keep away from moving shock. Run the connector with the green and white wire to the right side of the car to the right LED turn light, run the connector with the yellow and white to the left side LED turn light, connect the green wire to right black wire and yellow wire to left black wire and white to white on both. **NOTE: The Black LED wire is positive and goes to the yellow and green wires, they will not work if reversed, white is ground. Secure the Harness using the provided cable ties.**
5. Install the Horn. On the upper frame in the passenger wheel well is a ground strap, remove the bolt and install with the ground strap. Connect the Violet and Black wire to horn terminals, position does not matter.



6. Install the Turn and Horn/Hazard Switches. Remove 2 of the switch plugs.



Run Switch Harness–Plug the Switch Harness into the Control Module, run the two connectors through the rectangle switch cutouts and use included grease on the terminals then connect to turn switch and slide switch into dash.

**NOTE:** The switch cut outs are counter sunk, we have supplied 4 switch seals (2 for each Switch) to be used as spacers to keep it raised out of the indent to keep it from getting stuck.

7. Plug the Power Harness into the Control Module. Run the power wire to the Busbar, remove one of the blanks and plug into the Busbar.

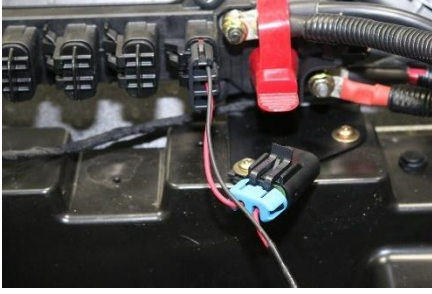

8. **Verify Operation:** The System uses momentary switches to activate. Turn the car key to the on position, Press the Right or Left Actuator accordingly. You can cancel the signal at any time by pushing the activated switch a second time or it will cancel as follows:

Press 1 Second for Lane Change, will stay on approx. 8 Seconds / 10 Flashes

Press 2 Seconds for Slowing to Turn Corners, will stay on approx. 20 Seconds / 30 Flashes

Press 5 Seconds for Traffic Lights when stopping and waiting, will stay on approx. 75 Seconds / 110 Flashes

The Systems Automatic Self-Cancelling may be overridden/Shut Off at any time by pushing the activated switch.

Hazard Lights - press to activate and press again to deactivate, it does not self-cancel. Test the Horn

9. Mount the Control Module using the screw provided. Mount just to the side of one of the holes for Relays



10. Using the provided Cable Tie's secure the harness completely. Reinstall any removed parts.

We can be reached by email at [support@xtcpowerproducts.com](mailto:support@xtcpowerproducts.com)

XTC Power Products  
A Division of XTC Motorsports LLC  
380 E Comstock Dr.  
Chandler AZ 85225  
480-558-8588

[www.xtcpowerproducts.com](http://www.xtcpowerproducts.com)

\*Disclaimer: This kit is intended for off road use only and XTC Motorsports claims no responsibility for its use. It is up to the purchaser to make sure it complies with all Federal, State and Local laws. R3.5

Copyright © 2023 XTC MOTORSPORTS LLC, all rights reserved.